

General Engineering for Tourney Car Construction
By Isabella de Boyce (OP OVO)

This work is to enhance the knowledge of period engineering and its application to tourney and guild cars as well as cars used in theater and religious productions during the Middle Ages. This work will not cover hydraulic, steam, weighted, mercury switches. Villard de Honnecourts notebooks mention a simple rope driven bird (eagle) and a rope a pulley apparatus for rotating a angel in 1254 (3). but we shan't be covering that either. Nor will it cover puppets. It will focus on the wide variety of motions that can be produced by simple wheel driven mechanisms, which existed in all their forms during the middle ages (3).

Tourney cars not only were used at the pageantry of the procession of the tourney but sometimes became part of the tournament themselves. Themes and disguises were popular (6). Besieging a castle was an extremely popular theme often becoming part of the tournament itself (6). One fortress in 1512 was so strong that it was determined that it could not be wonne by sport, by (sic) earnest". Henry VIII 1509 coronation had 4 tourney cars that showed a mountain, a forest, a park and a castle. When his son Henry was born a tournament was held in 1511, with a forest theme. The car was 26'1 x 16'w x 9'h. and featured all manner of sylvan themes, including 7 people (6). These tourney cars could be huge. The below, out of period etching shows one so large it has "walkers" beside it (5).

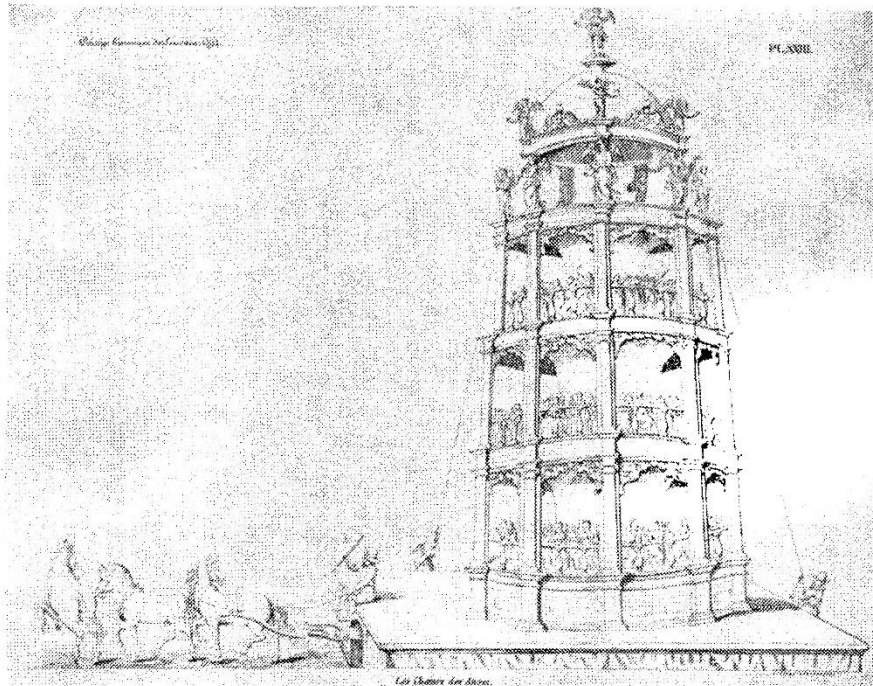
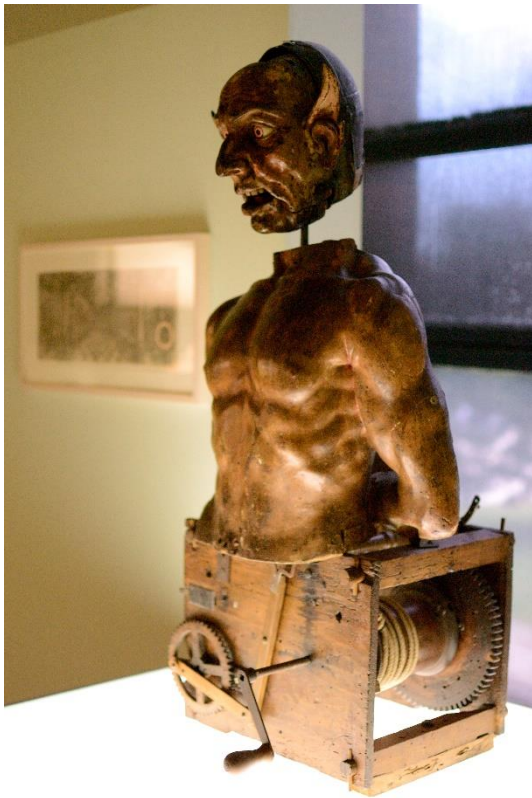

Plate 12. *The Nine Chairs of Angels.*

Examples of tourney cars and this type of technology off the tourney field all together can be found regularly throughout the Middle Ages. Although their use is no explained in Hill, the aforementioned eagle and angel can be sited in 1254. In the late 13th C, automations we also used in gardens. Duc Phillippes, Count of Artois, garden featured such things as the hair-covered apes in that reportedly needed frequent repair (6).

In the 15th C onward churches sported flying angels, suffering crucified Christ's, and terrifying devils. The one at the Castello Sforzesca in Milan rolls his eyes and wags his tongue.(10).





Scenery for the Valenciennes Mystery Play, 1547.
BnF MS Français 12536 f. 1v-2.

And a processional car with a mouth of hell that opened and closed exposing the horrors of the damned (7).

One of the written examples that discusses tourney cars, both religious and secular is an account from 1313 of Phillip the Fair's sons being knighted on Pentecost in Paris. The account is the first account of Parisian street tableau and takes up 83 lines of the account. It covers religious events and scenes from Reynard the Fox, a popular piece of literature at the time (1). A 40' by 20' car representing the City of Troy was brought into the hall in 1389 for Queen Isabelle (6). At Catherine of Aragon's wedding feast (1501) the tourney cars were brought into the feast hall (6). When possible I will use extant examples and show SCA applications. Otherwise I will use these listings illustrate how these mechanisms could have easily provided the described movements.

Since no examples exist of tourney cars, most of the documentation is written. There are some extant drawings of early Greek mechanical theaters that employ the motions involved. The person that did the "special effects" in medieval theater were called "the master of secrets" thus making us assume they did not write their Secrets down but passed them to trusted apprentices. What we do know is the following, all of which is taken from Hills book, *The History of Engineering* pages 207-209.

Components and Techniques

Most of our information about manufacturing and constructional methods comes to us from al-Jazari's work. This is because he gives us step-by-step instructions, describing the manufacture of a tank, for example, from the sheet of copper to the finished vessel. Other writers simply say 'A tank of 2 spans diameter, 5 spans long, is installed . . .' Although al-Jazari was a better engineer than most, it is reasonable to suppose that his predecessors' methods were similar to his, except where he makes it clear that a particular technique is of his own devising. Apart from some specialised water machinery, the components and techniques described in this section are also applicable to the construction of water-clocks. The subject can be conveniently divided into two categories — mechanical and hydraulic.

Mechanical

Wheels, Axles and Bearings. Wheels were nearly always pulleys, the small ones made of copper, the large ones of wood, both having semi-circular grooves in their rims to accommodate the ropes or cords. Large wheels were sometimes made of laminated timber to minimise warping and, if necessary, they were statically balanced; they were placed on a mandrel and checked for free rotation; if they were out of balance, small pieces of lead were fixed to the outer edge until balance was achieved. Quite often, especially in clocks, large pulley-wheels had to be precisely dimensioned, so that their rotation converted the travel of a float, for example, into a required circular or linear distance. Wheels were usually fixed rigidly to their axles. These could

be of wood, copper or iron, depending on the duty. Wooden axles had iron 'acorns' nailed to their ends and these protuberances were mounted in iron journals. In the terminology, distinctions were made between large and small horizontal bearings, and between these and vertical thrust bearings. There is no mention anywhere in the literature of lubrication.

Gears. All the combinations of gears appear in the automata treatises: parallel meshing; meshing at right angles; worm-and-pinion; rack-and-pinion. As we have noted, segmental gears appear in al-Murâdî and al-Jazarî and epicycle gears only in al-Murâdî. Larger wheels were usually made of wood, the teeth formed from pegs fixed around the perimeter; for parallel meshing one of the gears was often a lantern pinion. Smaller gears were made from copper or bronze, the teeth filed to the shape of equilateral triangles. In automata and water-clocks gears were rarely used in the main transmission system; their use was usually confined to peripheral mechanisms — pulley-trains were commonly used for transmitting power. Al-Murâdî's treatise has therefore three unique features: epicycle gears, the use of gears to transmit power, and the fact that the gear-wheels were all made of metal.

Figures. The material most commonly used for making the figures of humans, animals and birds was beaten copper. If the limbs of the head were required to move they were attached to the torso by hinges or pin-joints. Figures were also made from beaten brass and from wood; if the material was wood, parts were hollowed out only if the mechanisms were to be placed inside them. When lightness was essential al-Jazarî made his figures from papier mâché, but this material does not occur in the works of earlier writers. In the treatises of Philo, Hero and the Banū Mūsà the figures seldom make bodily movements; they are either static, or the whole figure moves rotationally or in a straight line. Many of al-Jazarî's figures, however, move parts of their bodies. Human figures turn their heads, raise their arms or move their legs, birds spread their wings, and so on. It is rather surprising that the medieval tales of animated man-made beings could have grown out of the rather passive simulacra of al-Jazarî's predecessors.

Fixings and Fittings. There were no wood-screws or nuts-and-bolts until after the end of the Middle Ages. Although mortise-and-tenon and dovetail joints had been known since ancient times, these are not

mentioned by the automata-makers, who used nails for joining timbers. Metal pieces were joined end to end by male/female joints (the same expression was used then). When several pieces were on the same axle, they were held in place by cotters — as in the astrolabe. The usual method of making rigid joints between two pieces of metal was by soldering. Hinges were of the pin-jointed type, but one-way hinges that could flex only in one direction found a special application in clockmaking. Ropes and cords were made from hemp or silk, chains from iron or copper, and wire usually from copper.

A note here, the forest scene mentioned earlier was pulled by a lion of gold damask and an antelope of silver damask, & which makes me speculate that they may have been fabric stretched over a wooden frame, (much like the sheets of copper) covering the power source.

When considering making a tourney car, first develop an idea. After developing an idea, a bit of back engineering is necessary. Ask yourself these questions.

What will the power source be?

What motion needs to occur?

What needs to spin?

Is it the wheel or the axle that drives the motion?

Period power sources range from children up to 4 horses, and possibly swans.

Two types of Axle construction:

Linchpin type: dark parts spin. The axle is stationary the wheels spin. This is better for light loads (Swartz pg 162).

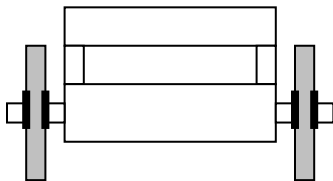

Free axle type: dark parts spin. Although the wheels spin, they are stationary to the axle and spin as a unit. This is better for heavy loads (Schwartz pg 162).

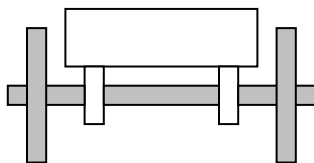

Next overall design should consider the power source.

Chinese Wheelbarrow: Free axle or linchpin.

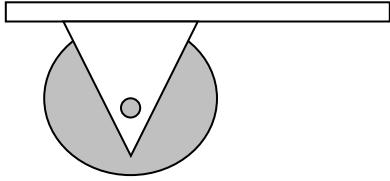

Pros: very maneuverable, doesn't stress the power source, needs constant attention
Cons: can't really set it down. Have to be careful with balance.

European Wheelbarrow:

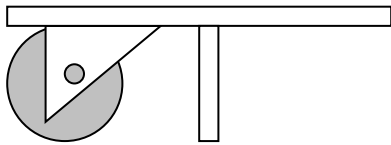

Pro: easy to maneuver.

Cons: cant really set it down. Angle creates problem stresses the power source.

Peddlars cart: According to EEEEEEE this was the most favoured type of cart in the Middle Ages. :

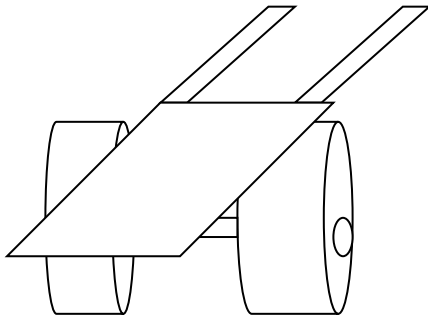

This extant piece dated 850 a.d. shows drastically different levels of workmanship. It shows crude fellies (wheel sections) and metal banding is yet to be rediscovered.